

# VOLKSWAGEN

AKTIENGESELLSCHAFT

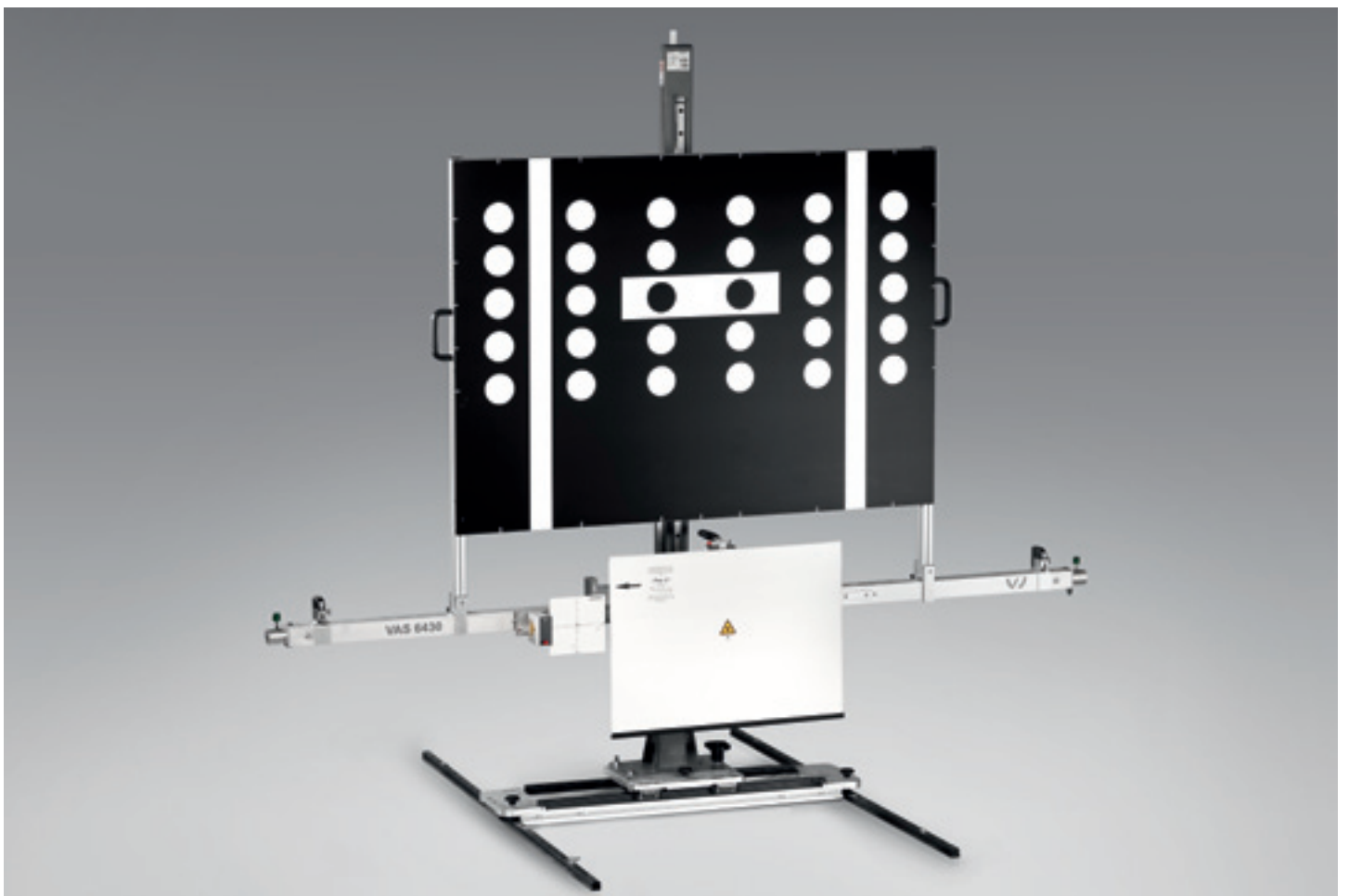

**VAS 6430P Adjustment jig**  
for ACC, lane departure warning, system front camera  
and night vision assistant



2 VAS 6430 ADJUSTMENT JIG

FOR ACC, LANE DEPARTURE WARNING, SYSTEM FRONT CAMERA AND NIGHT VISION ASSISTANT

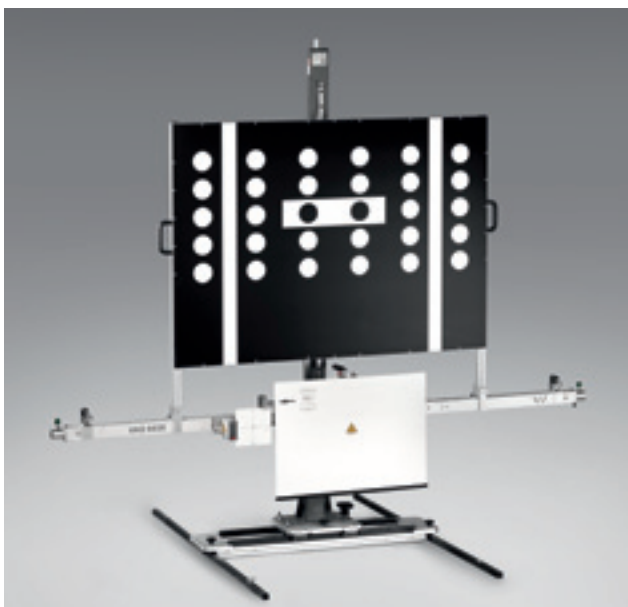
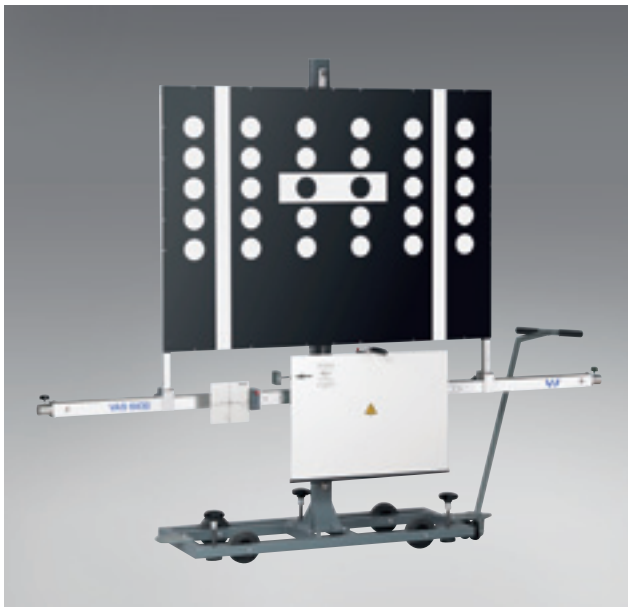

## VAS 6430, suitable for all manufacturers – mobile or stationary



### **VAS 6430 adjustment jig**

The VAS 6430 adjustment jig adjusts the radar sensor in the ACC and calibrates the image sensor in the lane departure warning system.

Adaptive cruise control (ACC) is an extension of the conventional cruise control system (CCS). The CCS regulates the vehicle's speed to a value preset by the driver. Automatic cruise control performs the same comfort feature while also adapting the vehicle's speed to a car in front if it is moving slower than your own. An electronic control system uses radar to measure the distance and relative speed to cars in front.

The lane departure warning warns the driver via vibration of the steering wheel if the vehicle unintentionally leaves the lane.

## VAS 6430 – for use in variable workplaces

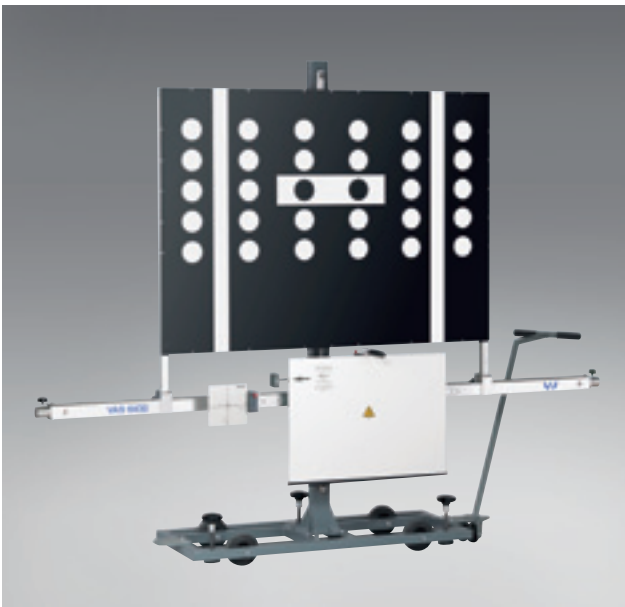

Workshops with limited space and an auto-lift workstation, are best serviced with the mobile VAS 6430.

### VAS 6430 adjustment jig

ASE 423210 00 000

The VAS 6430 adjustment jig adjusts the radar sensor in the ACC and calibrates the image sensor in the lane departure warning system.

The VAS 6430 adjustment jig with adapted VAS 6430/4 calibration map, together with the chassis measuring systems produced by VOLKSWAGEN AG, is adjusted to the geometric driving axis. The next step is to break in the sensors.

### Scope of delivery:

- 1 base frame with drawbar and 3 adjusting feet for setting up the base frame
- 1 carrier column with linear unit and one-man mechanism
- 1 adjustment bar with precision guidance for the ACC/ADR laser box or the ACC reflector mirror and the camera calibration map
- 1 ACC laser box, incl. VAS 6430/2 acoustic signal
- 1 Phaeton focusing screen with silkscreen
- 1 Passat focusing screen with silkscreen and adapter
- 1 ACC reflector mirror with laser unit and VAS 6430/3 acoustic signal
- 1 rough-adjustment mirror for AUDI ACC sensors
- 1 lane departure warning system calibration map, incl. frame and VAS 6430/4 precision levellers
- 1 distance measuring unit with tape measure and plug bolt (2 pieces)
- 1 assembly and operating manual

### Recommended accessories:

Adjuster tool VAS 6190/2

ASE 423063 00 000

## VAS 6430Profi – for workshops with fixed measuring stations

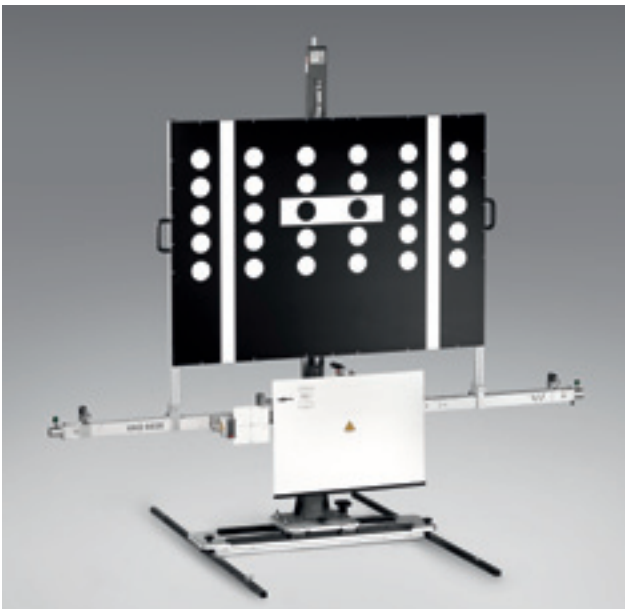

The VAS 6430P with the stationary base frame is deployed for a fixed auto-lift measurement station. This shortens the adjustment process and saves time.

### VAS 6430P adjustment jig

ASE 423 210 00 Y00

Beissbarth has now developed the VAS 6430/7 for workshops that always perform adjustments in the same workstation. The base frame, which functions as an XY slide gate with precision rails, is assembled on the floor in front of the lift and speeds up the adjustment process significantly, because no alignment time is required. Estimated time savings approximately 10 minutes.

### Scope of delivery:

- 1 base frame, stationary
- 1 carrier column with linear unit and one-man mechanism
- 1 adjustment bar with precision guidance for the ACC/ADR laser box or the ACC reflector mirror and the camera calibration map
- 1 ACC laser box, incl. VAS 6430/2 acoustic signal
- 1 Phaeton focusing screen with silkscreen
- 1 Passat focusing screen with silkscreen and adapter
- 1 ACC reflector mirror with laser unit and VAS 6430/3 acoustic signal
- 1 rough-adjustment mirror for AUDI ACC sensors
- 1 lane departure warning system calibration map, incl. frame and VAS 6430/4 precision levellers
- 1 distance measuring unit with tape measure and plug bolt (2 pieces)
- 1 assembly and operating manual

### Recommended accessories:

Adjuster tool VAS 6190/2

ASE 423063 00 000

## An overview of the VAS 6430 components

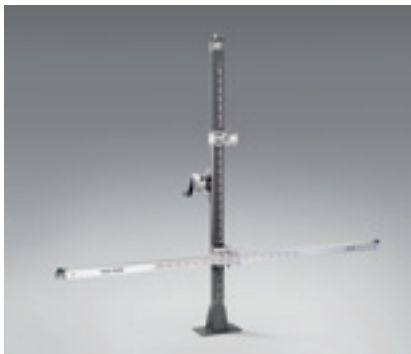

### VAS 6430/1 adjustment jig, basic kit

ASE 423211 00 000

The VAS 6430/1 A adjustment jig serves as a conversion kit for existing VAS 6041 ADR adjustment jigs and VAS 6190 ACC adjustment jigs. Using the conversion kit, it is possible to adapt the VAS 6430/4 lane departure warning system calibration map.

At the same time, the VAS 6430/1 A adjustment jig also serves as a basic kit for calibrating VW vehicles with VAS 6430/2 ACC laser units or for calibrating Audi vehicles with VAS 6430/3 ACC reflector mirrors. The VAS 6430/2 ACC laser units or VAS 6430/3 ACC reflector mirrors must be ordered separately.

#### Scope of delivery:

- 1 carrier column with linear unit and one-man mechanism
- 1 adjustment bar with precision guidance for the ACC/ADR laser box or the ACC reflector mirror and the VAS 6430/4 lane departure warning system calibration map
- 1 assembly and operating manual

#### Order additionally:

1 base frame, mobile VAS 6430/8	ASE 423 218 00 000
---------------------------------	--------------------

or / alternativ

1 base frame, stationary VAS 6430/7	ASE 423 217 00 000
-------------------------------------	--------------------

#### Recommended accessories:

VW ACC laser unit VAS 6430/2	ASE 423212 00 000
------------------------------	-------------------

Audi ACC reflector mirror VAS 6430/3	ASE 423213 00 000
--------------------------------------	-------------------

Lane departure warning system calibration map

VAS 6430/4	ASE 423214 00 000
------------	-------------------

Adjuster tool VAS 6190/2	ASE 423063 00 000
--------------------------	-------------------

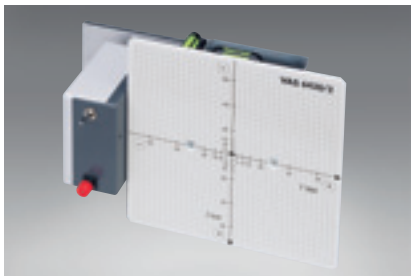

### VAS 6430/2 VW ACC laser unit

ASE 423212 00 000

Accessory for VAS 6430/1 adjustment jig.

The VAS 6430/2 ACC laser unit is needed, as an extension to the VAS 6430/1 adjustment jig, to adjust the ACC sensors on VW vehicles.

#### Scope of delivery:

- 1 VW ACC laser unit, incl. acoustic signal
- 1 Phaeton focusing screen with silkscreen
- 1 Passat focusing screen with silkscreen and adapter



### VAS 6430/3 Audi ACC reflector mirror

ASE 423213 00 000

Accessory for VAS 6430/1 adjustment jig.

The VAS 6430/3 ACC reflector mirror is needed, as an extension to the VAS 6430/1 adjustment jig, to adjust the ACC sensors on Audi vehicles.

#### Scope of delivery:

- 1 Audi ACC reflector mirror with built-in laser unit
- 1 rough-adjustment jig



#### **VAS 6430/4 lane departure warning system calibration map**

ASE 423214 00 000

Accessory for VAS 6430/1 A adjustment jig. The VAS 6430/4 calibration map is needed, as an extension to the VAS 6430/1 adjustment jig, to calibrate the image sensors on the lane departure warning system. The lane departure warning system warns the driver by vibrating the steering wheel if he inadvertently leaves his lane.

##### **Scope of delivery:**

- Calibration map, incl. frame and precision levellers
- Distance measuring unit with spring-tape measure and plug bolt (left/right)



#### **System calibration map VAS 6430/6 for night vision assistant**

ASE 423 216 00 000

Technological enhancement for calibration of the night vision assistant in combination with the base frame 6430/1 and the linear laser VAS 6350/3. The VAS 6430/6 is centrally positioned in the direction of travel with the aid of a wheel alignment unit and acts as reference heat source for the thermal imaging camera, which can be set in accordance with instructions from a diagnostic unit. Exclusive use is to be made with the VAS 6430/6 of wheel alignment equipment recommended by Volkswagen AG

##### **Scope of delivery:**

- 1 aluminium housing with printed circuit board assembly
- 1 power supply unit 230 V
- 1 assembly and operating manual

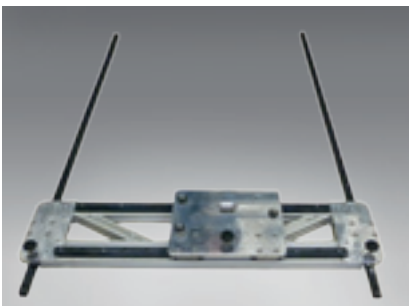

#### **Base frame, stationary VAS 6430/7**

ASE 423 217 00 000

Accessory for the setting device, VAS 6430 / VAS 6430/1 A.

The base frame, which functions as an XY slide gates with precision rails, is fixed to the floor. Assembly/retrofit can be performed by the partner on location; assembly instructions are included. Advantages: short set-up time (time savings of approximately 10 minutes) and no subsequent corrections for the alignment of the mobile base frame is required

##### **Scope of delivery:**

- 2 guide bars
- 1 cross link with accommodation for carrier column
- 1 assembly kit

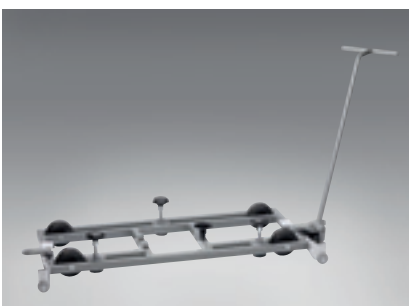

#### **Base frame, mobile VAS 6430/8**

ASE 423 218 00 000

Accessory for VAS 6430/1 adjustment jig. The mobile frame is required for the incorporation of the VAS 6430/1 adjustment jig. Base frame with drawbar and 3 adjustment feet for setting up the base frame

##### **Scope of delivery:**

- 1 base frame
- 1 drawbar
- 2 supports

© Volkswagen AG  
38436 Wolfsburg  
Germany

*For internal use only.  
Technical modifications are subject of change.  
Images may show special accessories not included  
in standard delivery program.*

*Version: March 2014*